

Encore® Tankless  
Gas Water Heaters  
from Richmond®

**Richmond**®  
The Water Heater Experts

# CONDENSING TANKLESS

**RMTGH-95DV indoor direct vent and  
RMTGH-95X outdoor natural and LP models –  
11,000 - 199,900 BTU max.**

9.5 gal./min at 35° F rise max., 8.4 gal./min. at 45° F rise

Limited Warranty:

**12-Year on heat exchanger, 5-Year on parts,  
1-Year on labor**

See Residential Warranty Certificate for complete warranty information.

- 94% efficient with stainless steel condensing heat exchanger
- 2-Pipe Direct Vent System designed for PVC Pipe, See instructions for details
- Up to 35 ft. of 3" PVC Pipe or 5 ft. of 2" PVC Pipe, See instructions for details
- **Exclusive!** Integrated Condensate Neutralizer
- **Industry Best!** .26 GPM Minimum Flow Rate, .40 GPM Minimum Activation Flow Rate
- **Exclusive!** Overheat film wrap (OFW)



See reverse for specifications.

[richmondwaterheaters.com](http://richmondwaterheaters.com)

# Encore® Condensing Tankless Gas Water Heaters from Richmond®

## Specifications

DESCRIPTION			FEATURES					ROUGHING IN DIMENSIONS (SHOWN IN INCHES)						ENERGY INFO.			
MODEL NUMBER	GAS INPUT BTU/HR.	TYPE	TEMP. RANGE	MIN. FLOW /ACTIVATION GPM	GPM @ 77° RISE MAX.	GPM @ 45° RISE MAX.	MAX. GPM	CONNECTION		HEIGHT	WIDTH	DEPTH	VENT DIAMETER	SHIP. WEIGHT (LBS.)	ENERGY FACTOR	% OF THERM. EFFICIENCY	D.O.E. ANN. OP. COST NAT/LP
								WATER	GAS								

RICHMOND CONDENSING TANKLESS WATER HEATERS FOR 3 BATHROOM HOMES																	
RMTGH-95DVN*	11,000-199,900	Indoor Direct Vent	85° to 140° F*	.26/40	4.9	8.4	9.5	3/4	3/4	27-1/2	18-1/2	9-3/4	3" PVC 2-Pipe	82	.94	94%	194/326
RMTGH-95XN*	11,000-199,900	Outdoor	85° to 140° F*	.26/40	4.9	8.4	9.5	3/4	3/4	27-1/2	18-1/2	9-3/4	N/A	82	.94	94%	194/326

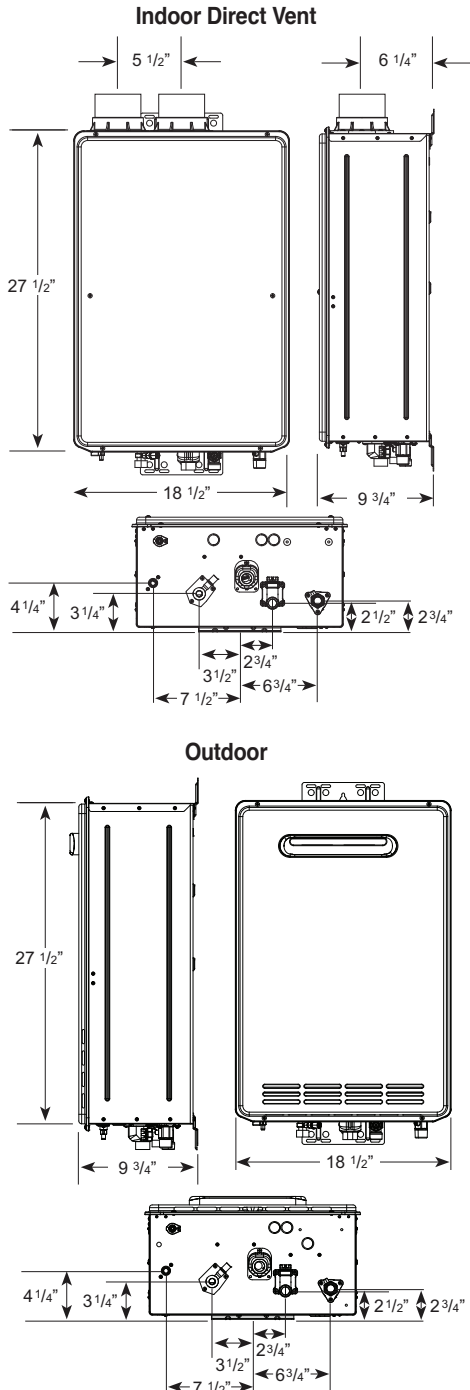

Energy Factor and Average Annual Operating Costs based on D.O.E. (Department of Energy) test procedures. D.O.E. national average fuel rate natural gas \$1.218/therm; LP \$1.87/gallon.

All models are available in Natural Gas and Propane (LP). For Propane replace the N with P when ordering.

- Factory set maximum temperature is 120° F. See Use and Care Manual for setting.
- Consult factory for information on sizing the application.

Vent Termination Kits are required for Direct Vent models. Contact your distributor for details.

Proper gas pressure must be ensured to supply tankless gas water heaters – up to 199,900 BTU for RMTGH-95 models. (Consult your gas supplier)

Model Number	Temperature Rise (° F)								
	35°	45°	50°	60°	70°	77°	80°	90°	100°
RMTGH-95 Water Flow (GPM)	9.5	8.4	7.6	6.3	5.4	4.9	4.7	4.2	3.8

Above estimates are for sizing purposes only.

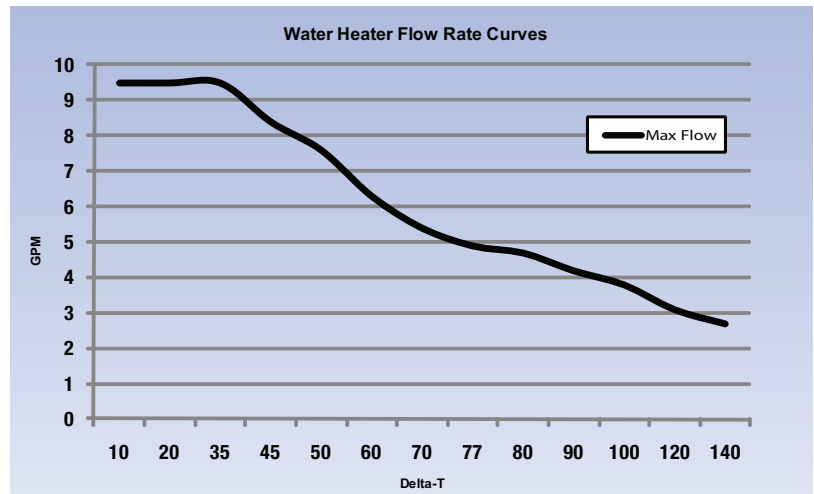

These units are designed to meet or exceed ANSI (American National Standards Institute) requirements and have been tested according to D.O.E. test procedures and meet or exceed the energy efficiency requirements of NAECA, ASHRAE standard 90, ICC Code and all state energy efficiency performance criteria for energy consuming appliances.

Before purchasing this appliance, read important energy cost and efficiency information available from your supplier.

In keeping with its policy of continuous progress and product improvement, Richmond reserves the right to make changes without notice.

Richmond Water Heaters  
 101 Bell Road  
 Montgomery, AL 36117  
 800-621-5622  
[www.richmondwaterheaters.com](http://www.richmondwaterheaters.com)

